



Apartment Three-bedroom (4+kk)

Ask for price

127 m², Praha 10, Strašnice, Solidarity





Apartment Three-bedroom (4+kk)

Ask for price

127 m², Praha 10, Strašnice, Solidarity

| | |
|------------------|--------------------|
| Total area | 127 m ² |
| Garden | 92 m ² |
| Parking | - |
| Cellar | - |
| Reference number | 100976 |

This completely renovated apartment with the parameters of a family house with a cozy interior and a west-facing landscaped garden is located in one of the greenest parts of Prague's Strašnice district, within easy reach of all civic amenities and public transport stations.

The unit's ground floor consists of a living room, an adjoining kitchen with a window, an entrance hall, a separate toilet, and a closet. On the 1st floor are 2 bedrooms and a bathroom (with a bathtub, shower, and toilet). A large bedroom extends over the entire attic. The living room has access to the garden terrace.

Facilities include **wooden plank floors**, **wooden stairs**, built-in wardrobes, and a fully equipped kitchen. The **fireplace** in the living room creates a cozy atmosphere. The primary heating source is a gas boiler.

The residential district, with its **authentic atmosphere**, was built in the middle of the 20th century. It stands out for its **abundance of greenery**, streets lined with mature trees, and several nearby playgrounds. The building is located right next to **Na Solidaritě Park**, close to shops, cafes, a kindergarten, an elementary school, and a tram stop. A metro station (line A) is also within walking distance.

Floor area 127m², garden 92 m², plot of land 148 m².

The property is approved as a housing unit.

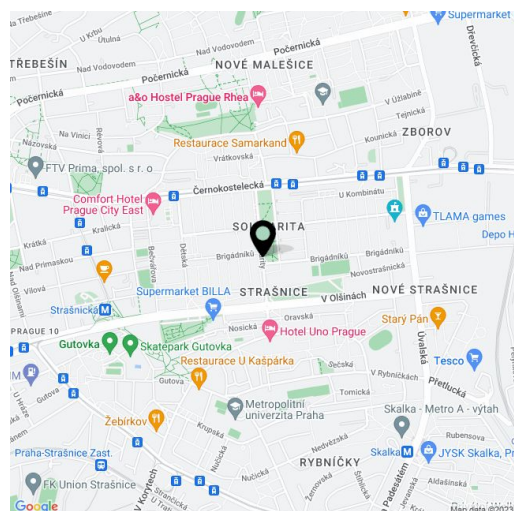

* Area of the unit according to the Civil Code. The area consists of the sum total area of the entire unit bounded by perimeter walls.



Apartment Three-bedroom (4+kk)

Ask for price

127 m², Praha 10, Strašnice, Solidarity

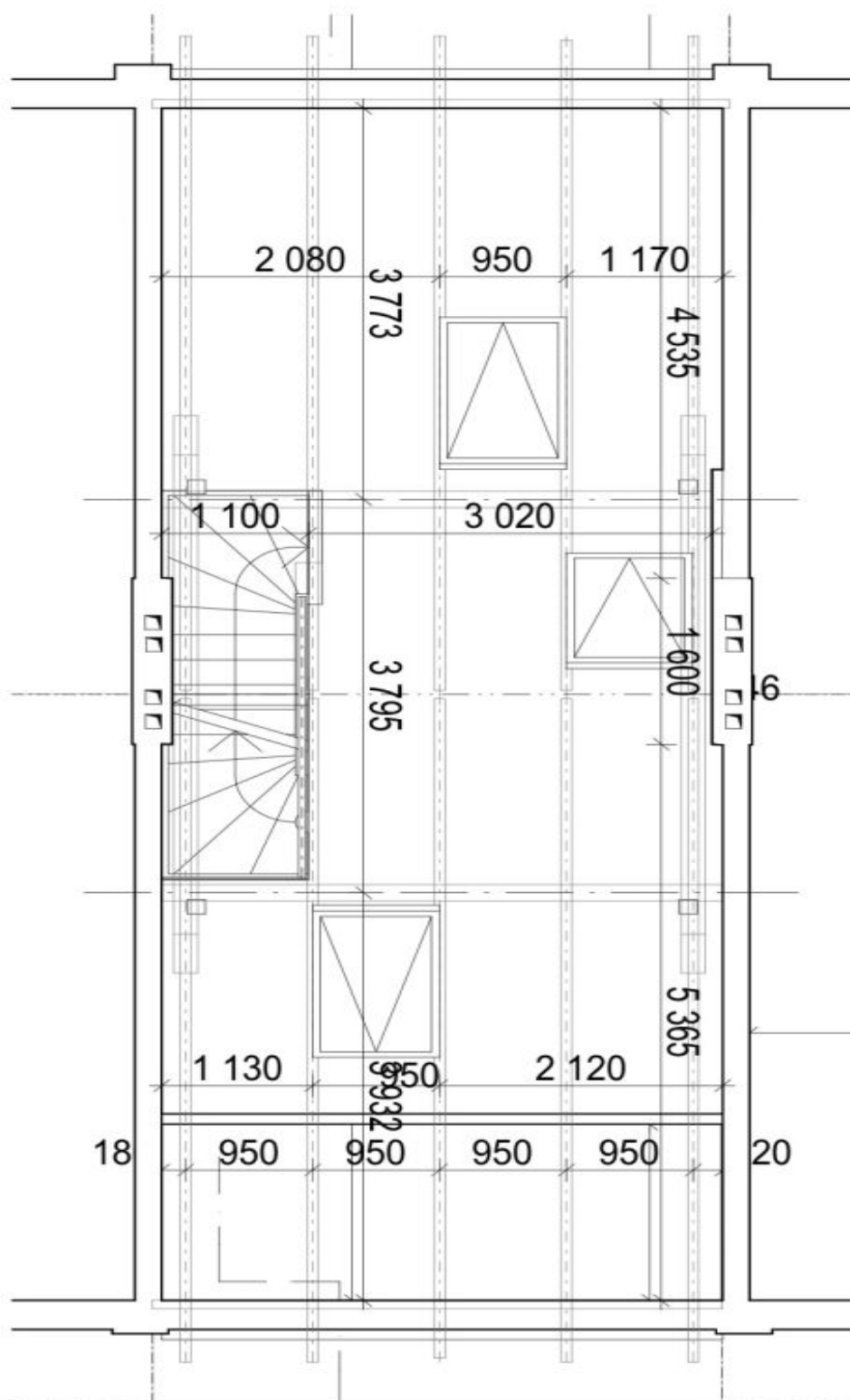



Apartment Three-bedroom (4+kk)

Ask for price

127 m², Praha 10, Strašnice, Solidarity

| Tabulka místností 2.NP | | | | | | | |
|------------------------|-----------------|--------------------------|-------------------------|---------|-------------------------|-------------------------|----------|
| Číslo místnosti | Název místnosti | Plocha (m ²) | podlaha | skladba | stěny 1 radek | strop 1 radek | poznámka |
| 05 | CHODBA | 5,07 | keram.dlažba, soklik 80 | P4 | om, VPC, štuk, 2x malba | om, VPC, štuk, 2x malba | |
| 06 | POKOJ | 16,05 | laminat, podl. lišta 50 | P2 | om, VPC, štuk, 2x malba | om, VPC, štuk, 2x malba | |
| 07 | POKOJ | 14,88 | laminat, podl. lišta 50 | P2 | om, VPC, štuk, 2x malba | om, VPC, štuk, 2x malba | |
| 08 | KOUPELNA | 6,14 | keram.dlažba | P4 | ker.obklad v 2100mm | om, VPC, štuk, 2x malba | |
| | | 41,94 m ² | | | | | |

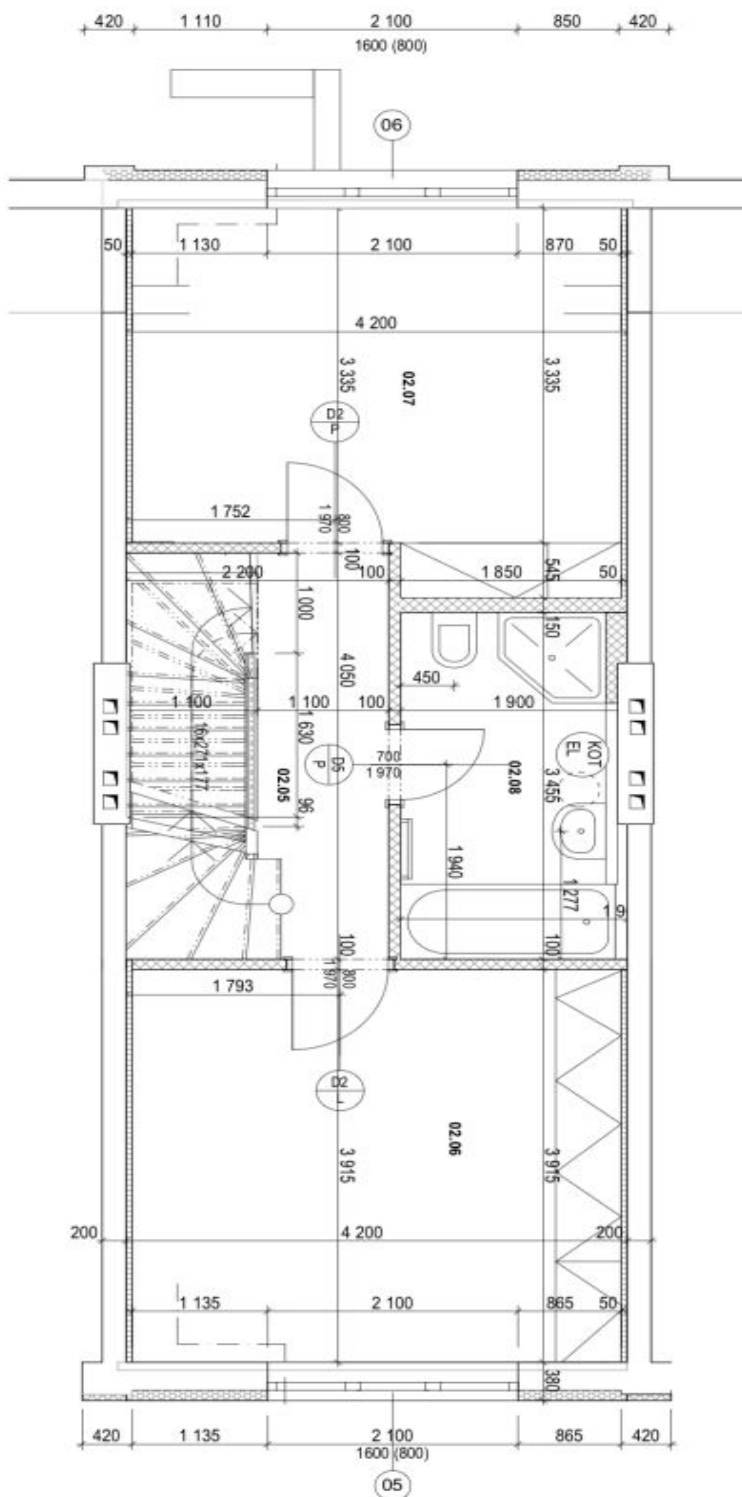

S





Apartment Three-bedroom (4+kk)

Ask for price

127 m², Praha 10, Strašnice, Solidarity

| Tabulka místnosti 1.NP | | | | | | | |
|------------------------|-----------------|--------------------------|-----------------------------|---------|-------------------------|-----------------------------|--------------------|
| číslo místnosti | Název místnosti | Plocha (m ²) | podlaha | skladba | stěny 1 řadek | strop 1 řadek | poznámka |
| 01 | CHODBA | 4,96 | keram. dlažba, soklik 80 | P4.1 | om. VPC, štuk, 2x malba | om. VPC, štuk, 2x malba | |
| 02 | WC | 1,36 | keram. dlažba | P4.1 | ker. obklad, v 2100mm | om. VPC, štuk, 2x malba | |
| 03a | OBYVACÍ POKOJ | 28,33 | parketová podlaha, líska 50 | P2.1 | om. VPC, štuk, 2x malba | om. VPC, štuk, 2x malba | |
| 03b | KUCH. KOUT | 7,74 | keram. dlažba, soklik 80 | P4.1 | om. VPC, štuk, 2x malba | om. VPC, štuk, 2x malba | obklad za kuch. k. |
| 04 | SKLAD | 2,53 | keram. dlažba, soklik 80 | P4.1 | om. VPC, štuk, 2x malba | schodišťový dřevěný podhled | snižená výška |
| | | 44,92 m ² | | | | | |

