



House Three-bedroom (4+kk)

Rented

168 m², Praha 6, Střešovice, Klidná





House Three-bedroom (4+kk)

Rented168 m², Praha 6, Střešovice, Klidná

Plot	261 m ²
Foot print	143 m ²
Garden	118 m ²
Parking	Parking on the plot.
Cellar	Yes
Service price	Deposit for services CZK 5,500/month. Gas and electricity are paid separately (transferred to the tenant).
PENB	G
Reference number	20503
Available from	Immediately

Boasting a prestigious location, this completely refurbished 1920s town house is situated in the heart of the exclusive Ořechovka neighborhood with mature trees, parks, and distinguished villas. A location with quick access to the city center, Prague Castle, international schools and the airport, and within easy reach of the Dejvická and Hradčanská metro stations.

Ground floor: living room with a fully fitted open plan kitchen and access to the terrace and private garden, guest toilet, entry hall, and walk-in closet. First floor: two bedrooms, walk-in closet, bathroom. Second floor: a spacious air-conditioned attic bedroom, bathroom. Basement floor: laundry/boiler room with storage space.

Preserved original features, hardwood parquet floors, tiles, built-in wardrobes, French windows, washer, dryer, dishwasher, alarm, audio entry phone. One parking space in front of the house. Utilities are billed separately.

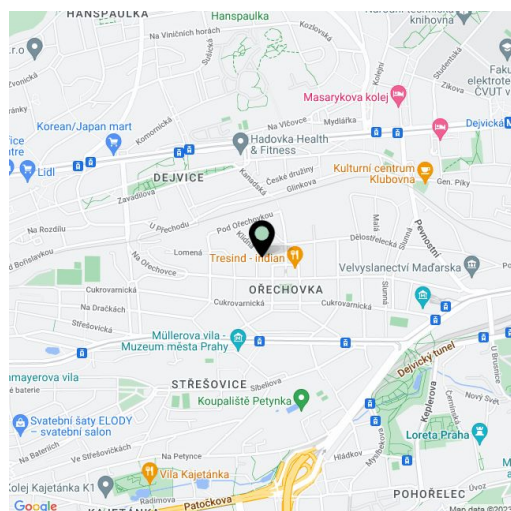



House Three-bedroom (4+kk)

168 m², Praha 6, Střešovice, Klidná

Rented

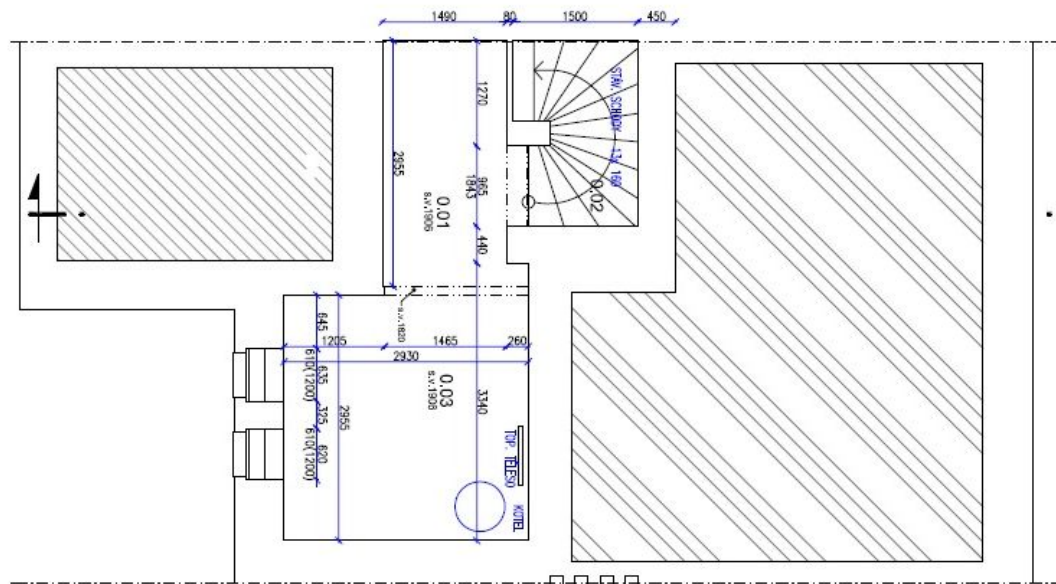

TABULKA MÍSTNOSTI 1. PP		
Č.M.	MÍSTNOST	m ²
0.01	OBÝVACÍ	4.23
0.02	SKLOPISŤE	3.03
0.03	KOTELNA, PRADELNA	9.33
CELKOVÁ PLOCHA		16.59



House Three-bedroom (4+kk)

168 m², Praha 6, Střešovice, Klidná

Rented

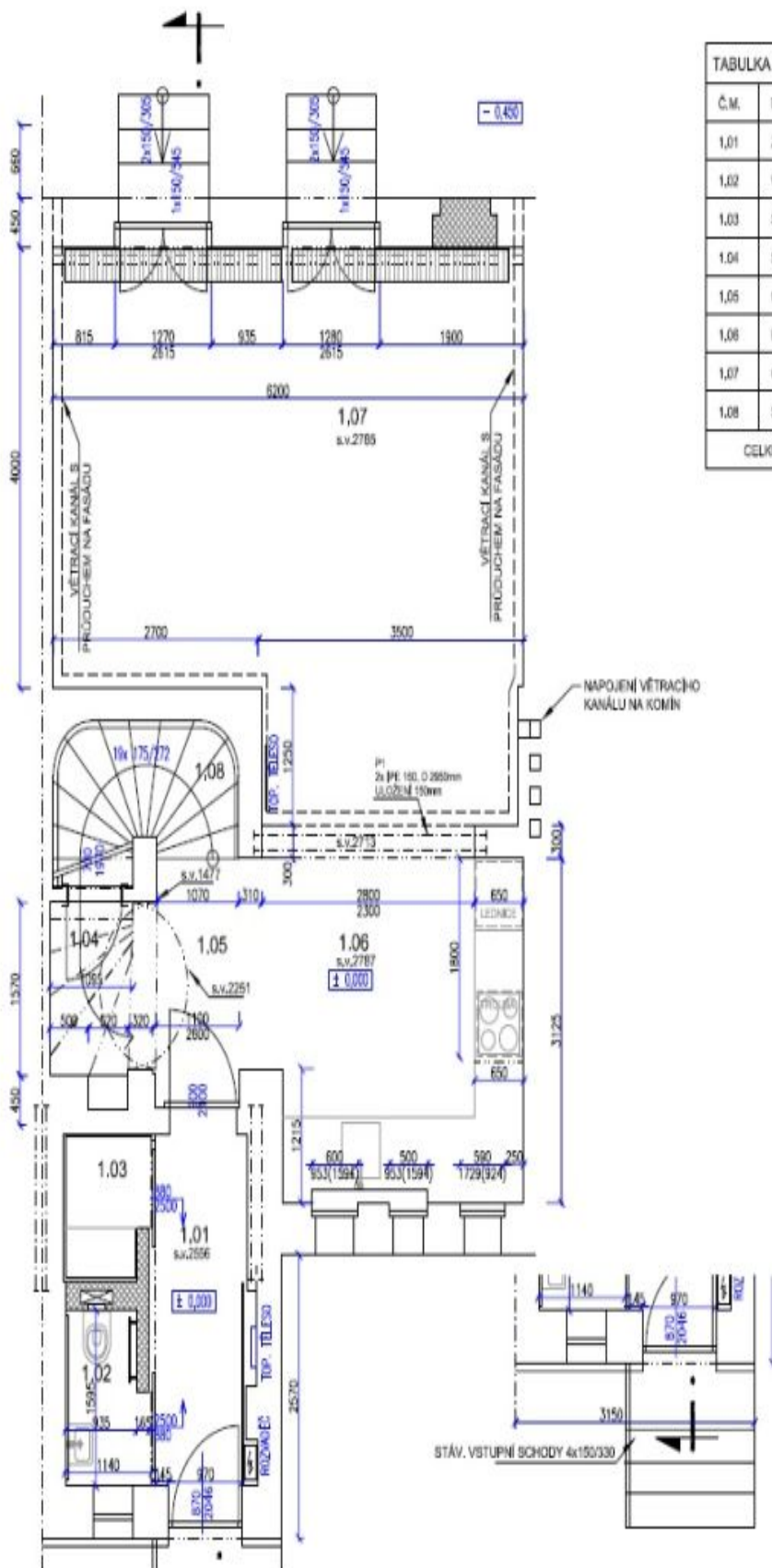

Č.M.	MÍSTNOST	m ²
1.01	ZÁDVEŘÍ	4,43
1.02	WC	1,88
1.03	ŠATNÍK	1,36
1.04	SPIŽ	2,21
1.05	CHODBA	2,41
1.06	KUCHYŇ	11,95
1.07	OBÝVACÍ POKOJ	31,8
1.08	SCHODY	1,57
CELKOVÁ PLOCHA		55,12



House Three-bedroom (4+kk)

168 m², Praha 6, Střešovice, Klidná

Rented

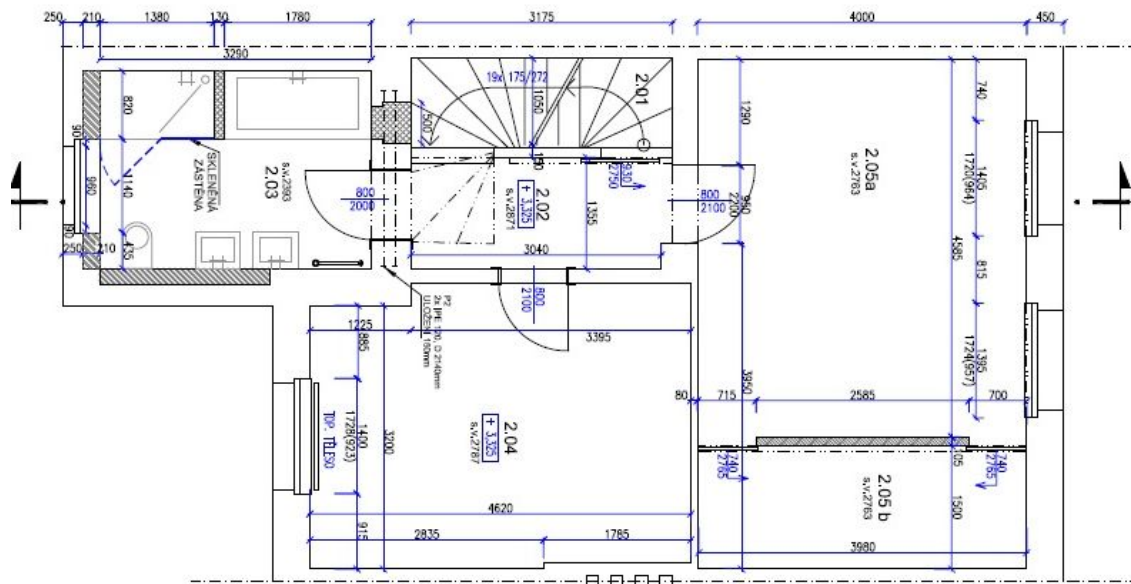

TABUĽKA MÍSTNOSTÍ 2. NP	
Č. M.	MÍSTNOST
2.01	SCHODY
2.02	CHODBA
2.03	KOUPELNA
2.04	DĚTSKÝ POKOJ
2.05a	LOŽNICE
2.05b	SÁLNÍK
CELKOVÁ PLOCHA	
	168,90



House Three-bedroom (4+kk)

168 m², Praha 6, Střešovice, Klidná

Rented

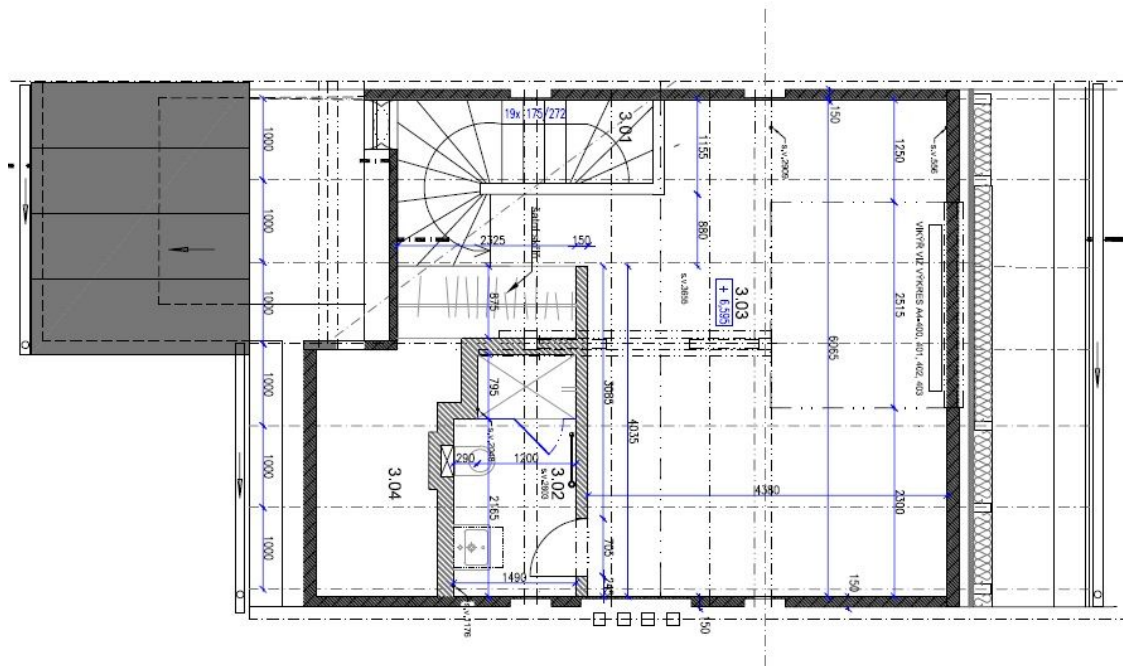

TABULKA MÍSTNOSTÍ 3. NP		
C.M.	MÍSTNOST	m ²
3.01	SCHODY	4,30
3.02	KOUPELNA	4,23
3.03	PRACOVNA/POKOJ	28,40
3.04	SPALOVNA	4,40
CELKOVÁ PLOCHA		38,48